

- 1.00 General..... 2
 - 1.01 Scope..... 2
 - 1.02 Codes and Standards Requirements..... 2
- 2.00 Design..... 2
 - 2.01 General..... 2
- 3.00 Products 4
 - 3.01 Hydraulic Assembly..... 4
 - 3.02 Charge pump and motor..... 4
 - 3.03 Basic Sediment and Water (BS&W) Monitor:..... 5
 - 3.04 Sampling System 5
 - 3.05 Meters..... 7
 - 3.06 Meter Temperature Devices 8
 - 3.07 Flow Computer/PLC Control Unit 8
 - 3.08 Prover Manifold 8
 - 3.09 Locks and/or Seals..... 9
 - 3.10 Instrumentation and Electrical 9
 - 3.11 Marking..... 10
- 4.00 Meter Operations and Proving 10
 - 4.01 Operation..... 10
- 5.00 Meter Tickets 11
 - 5.01 Requirements..... 11
- 6.00 Installation 12
 - 6.01 Electrical Wiring 12
 - 6.02 Controls..... 12
- 7.00 Appendix - Typical LACT Unit..... 13

Notes to the user and optional entries are indicated with this formatting.

1.00 GENERAL

1.01 SCOPE

- A. The purpose of this specification is to cover the design, fabrication, testing and preparation from shipment of skid mounted Lease Automatic Custody Transfer (LACT) Units.
- B. Requirements on equipment performance, facility design and control of custody transfer equipment are included in this standard.
- C. Liquids (up to 50° API @ 60 °F) covered by this standard are measured, and quantities calculated on a volume basis in terms of United States Barrel, 42 gallons at 60 °F and atmospheric pressure (14.73 PSIA).

1.02 CODES AND STANDARDS REQUIREMENTS

- A. The primary reference document of this standard is the API Manual of Petroleum Measurement Standards (API MPMS). API Specification 11N (Spec 11N), API RP 500, and all recognized industry codes and standards pertaining to the design of custody transfer measurement shall be followed. This includes, but is not limited to, publications by the National Institute of Standards and Technology (NIST, formerly NBS), American Society for Testing and Materials (ASTM), National Fire Prevention Association (NFPA), National Electric Code Association (NECA), and National Association of Corrosion Engineers (NACE).
- B. Pressure vessels and tanks associated with a LACT unit shall be designed and fabricated in accordance with the ASME Boiler and Pressure Vessel Code.
- C. Piping shall be designed and fabricated per ANSI B31.4 Liquid Transportation Systems for Hydrocarbons, Liquid Petroleum Gas, Anhydrous Ammonia and Alcohols.
- D. All applicable environmental and safety regulations and guidelines shall be observed. All local, state and federal regulations shall be followed within their jurisdictional limits.

2.00 DESIGN

2.01 GENERAL

- A. All equipment shall be in compliance with the performance and accuracy provisions of API MPMS. Each LACT Unit shall be capable of demonstrating a traceability to NIST standards.
- B. All LACT Units shall be designed for fail safe operation in cases of failure or malfunction so that un-sampled, off specification, or unmeasured liquids will not flow through custody transfer facilities. Status and failure indicators (alarms) shall be provided to facilitate identification of equipment failures and malfunctions.
- C. All equipment shall be designed and installed to be easily accessible for inspection, testing, calibration, and routine maintenance. This includes the recommended use of flexible conduit at least 18 inches long to connect each electrical device to rigid conduit. For piping components, it includes the use of isolation valves and unions, clamped couplings, or flanged connection for removal of equipment.

- D. All materials used in custody transfer equipment shall be compatible with the internal and external environments. Materials shall not experience excessive corrosion embrittlement, degradation, or physical property changes that affect the serviceability of the equipment.
- E. Materials containing crude oil under pressure shall also be ductile and resistant to fire exposure. Nonmetallic materials, such as plastics, shall not be used. Cast Iron, brass, bronze, copper, aluminum and zinc shall not be used in pressure containing components.
- F. A typical LACT Schematic is shown in Appendix A, Figure A-1.
- G. Each LACT Unit skid shall have, as a minimum, the following components:
 - 1. Charge Pump: See section 3.02 for complete description.
 - 2. Basic Sediment and Water (BS&W) Monitor: See section 3.03 for complete description.
 - 3. Diverter Valve: A three-way, two position valve or two mechanically interlocked valves shall be provided on all LACT Units where excess BS&W liquids are to be circulated for retreating. Flow shall be normally directed to the diverted (wet) discharge piping for fail-safe hookup. This valve shall be activated by the BS&W monitor such that the valve moves to divert flow to the clean oil discharge only when it receives a positive signal and it fails "safe" with flow to the wet oil discharge in the absence of a positive signal. If a diverter valve is not used, the wiring shall be configured to shut down oil delivery upon failure to receive a "clean oil" signal from the monitor.
 - 4. Strainer and Air/Gas Eliminator: The air/gas eliminator and strainer, as separate or integral units, shall be located upstream from the meter in a horizontal pipe. The air/gas eliminator shall be installed higher than the meter, at or near the highest location in the LACT Unit piping. The strainer element shall be equipped with a 4-mesh basket with a finer mesh lining. A 20-mesh or finer liner shall be furnished for use during the first 24 hours of operation.
 - 5. Static Mixer: An in-line static mixer shall be installed upstream of the sample probe. See section 3.04.A..1 for location details.
 - 6. Sample Systems: See section 3.04 for complete design.
 - 7. Back Pressure Valve[s]: An adjustable back pressure valve shall be located downstream of the meter Prover connections. The valve shall be a spring loaded or electrically actuated, globe or angle style valve with a resilient seat and corrosion resistant trim. It shall be closed under no flow conditions and shall fail in a closed position. **If re-treating line present, a back pressure valve or other restriction device shall be provided on the re-treating line and shall have the same pressure setting as the outlet control valve.**
 - 8. Check Valve: A check valve shall be installed at the outlet of each meter run, downstream of the back pressure valve.
 - 9. Meter: See section 3.05 for a complete description.
 - 10. Flow Computer: See section 3.07 for a complete description.
 - 11. Prover Manifold: See section 3.08 for a complete design.

- 12. Control Panel: Controls for the LACT facilities shall be in an enclosure that is resistant to the elements, tampering, vandalism and fire exposure. The control panel shall have separate power and control enclosures. See section 3.10 for a complete description.
- 13. Mounting Skid: The equipment components should be mounted on a sliding type, welded, oil-field style, structural steel skid designed with sufficiently sized members and bracing to provide a completely portable unit.
- H. All equipment components should be rigidly attached to the skid and braced as necessary, using suitable connections for those items likely to require future removal for normal repairs and maintenance.

3.00 PRODUCTS

3.01 HYDRAULIC ASSEMBLY

- A. The hydraulic assembly shall be made of Schedule 40 steel line pipe and fittings.
- B. Piping size for all elements directly in the main flow stream shall be no less than the nominal size of the meter.
- C. The hydraulic assembly of the main flow stream shall be connected using raised face flanges unless otherwise specified by the user.
- D. All piping and structural components should be commercially blasted, and painted with at least one coat of metal primer.

3.02 CHARGE PUMP AND MOTOR

- A. Pump shall be electrically driven, rated for a discharge pressure and rate that are compatible with the rating for the meter used, and sized to assure turbulent flow in the main stream piping.
- B. A centrifugal pump shall be supplied. Reciprocating and positive displacement pipeline pumps shall not be used. The pump shall conform to ANSI B73.1 or other applicable standard governing the pump type and design.
- C. The pump shall be capable of providing **20 psig** minimum over the RVP of the metered product at the LACT unit discharge at the maximum flow rate.
- D. The pump should be directly coupled to the motor with a flexible coupling, complete with guard.
- E. The pump should have a mechanical seal.
- F. A drip pan and drain piping shall be provided under the pump for spill protection in the event of a seal leak.
- G. The common base plate for the pump and motor should allow vertical and horizontal adjustment for alignment relative to each other without moving the base plate on the skid.
- H. Pump internal materials shall be appropriate for the specified service.
- I. An eccentric reducer shall be used if the inlet pipe is larger than the inlet connection of the pump.

- J. The motor should be 460 volt AC, 1800 RPM, 3 phase, sized to prevent overloading by the pump. Higher speed pumps are permitted to meet specified operating conditions with approval from the owner.

3.03 BASIC SEDIMENT AND WATER (BS&W) MONITOR:

- A. Probe installation is required in a vertical run of pipe as close downstream of the charge pump, static mixer, or other mixing element as is possible. End connections (if applicable) are required to facilitate removal of the probe for internal inspection and cleaning.
- B. The instrument shall have:
 - 1. Adjustable range: 0-3 percent water in increments of 0.1 percent water.
 - 2. Time delay for diverter action: 0-2 minutes (adjustable when specified).
 - 3. Means for field calibration.
 - 4. Fail-safe relay for delivery shutdown in event of a monitor failure.
- C. Meters and push buttons for performing operational checks and field calibration shall be provided. The monitor shall provide an indication of whether merchantable oil or excess BS&W is in the probe.
- D. The monitor chassis shall be either explosion proof or mounted in a weatherproof, dust tight enclosure. The limit setting and graduated indicator shall be visible when the monitor is sealed or locked.

3.04 SAMPLING SYSTEM

- A. Sample Probe Location.
 - 1. The probe may be installed in either a vertical or horizontal pipe run.
 - a. In a vertical pipe run, the probe shall be installed with at least three pipe diameters of straight pipe upstream and two pipe diameters of straight pipe downstream of the probe. The static mixer shall be installed within two pipe diameters of the probe.
 - b. In a horizontal pipe run, the static mixer shall be installed within one to two pipe diameters of the probe.
 - 2. A manual sample probe shall be installed three pipe diameters downstream of the automatic sample probe in order to take hand samples.
- B. Sample Probe Design
 - 1. The sample probe shall be located only in the horizontal plane and it shall extend such that the tip opening is located in the middle one-third of the pipe facing upstream.
 - 2. Acceptable sampling tip designs include:
 - a. Open end with 45 degree bevel.
 - b. Open end 90 degree tube turn reamed to a sharp entrance edge.
 - c. Closed end with round orifice entrance near the tip.
- C. Sample Extraction System

1. The sample probe shall be connected to a three-way solenoid valve with a volume regulator as close as practical but not greater than 10 inches. The piping shall be level or slope down to the valve and shall not be 3/8 inch in diameter. Refer to the Typical LACT Schematic in Appendix A, Figure A-1.
 2. **The sample probe shall be connected to a sample extractor as close as practical, but not greater than 10 inches. The piping shall be level or slope down to the valve and shall be 3/8 inch in diameter. Upstream of the sample valve shall be a circulating loop that discharges upstream of the LACT charge pump.**
 3. The sampler shall be flow responsive (proportional) type, actuated by an impulse switch driven by the meter counter. Unless otherwise specified, the impulse switch shall give one impulse per barrel (adjustable).
 4. The tubing between the three-way valve [**sample extractor**] outlet and the sample container shall be stainless steel, as short as practical, and shall be 3/8 inch in diameter, and continuously slope downward to the container without sags or loops.
 5. Fluid shall flow through three-way solenoid valve [**sample extractor and circulating loop piping**] at a velocity at least equal to the primary piping velocity.
 6. The piping shall contain a check valve to prevent back flow from the sample container.
- D. Sample container and circulating system.
1. A sample container shall be designed and installed to prevent vaporization of the stored sample.
 - a. The container shall be epoxy [**plastic**] coated (or equal) to minimize wax deposits and container corrosion. The sample container coating shall be of a color to allow effective inspection and cleaning.
 - b. The container shall be designed to withstand an internal pressure of 12 psig and be hydrotested for at least one hour to verify pressure containment capability.
 - c. The container shall be equipped with a quick opening type, vapor proof top inspection hatch designed to hold the sample under a pressure sufficient to prevent the escape of vapor.
 - d. The container shall be properly sized with respect to the expected volume per batch or ticket period at a fill volume of 80% of container volume capacity.
 - e. An internal spray bar to “wash” the container tip and sides and promote circulation of liquids within the container shall be provided.
 - f. The bottom of the container shall be so constructed that there are no voids in which a portion of the sample can be entrapped so that it is not subject to mixing by the circulation pump.
 - g. A level indicating transmitter shall be installed to indicate the volume of the sample contained.
 - h. **A full length sight glass, protected to avoid breakage, shall be installed along with a graduated scale with graduations of 0.1 gallons or smaller.**
 - i. A pressure relief valve shall be provided and set to the design pressure of the container. The set pressure shall be no less than 8 psig and no more than 10 psig.

- j. **Pressure required for controlling vaporization may be provided by means of an internal flexible diaphragm that is vapor impervious upon which a regulated gas pressure is maintained. Under no condition shall gas pressure from an outside source be applied in direct contact with the sample.**
 - k. A pressure gauge shall be provided.
 - l. A vacuum breaker to permit liquid withdrawal shall be installed.
 - m. A high level sensor shall be installed that shall alarm on high level and discontinue operation of the charge pump. The high level switch shall be installed at the 75-80% fill volume level.
2. A circulation pump shall be installed below the sample container to allow a complete blending of the sample into a homogeneous mixture before and during the withdrawal of a portion of the sample for testing.
 3. The pump shall be an electric motor driven rotary displacement or centrifugal pump with a capacity equal to the sample container size per minute, i.e., five GPM for a five-gallon container.
 4. The pump suction shall be connected to the bottom most point of the sample container and the discharge shall be connected to the internal spray bar. The piping shall be 3/4 inch or larger on both the suction and discharge of the mixing pump.
 5. **An in-line static mixer on the discharge of the mixing pump shall be installed.**
 6. A sample draw valve and fill connection shall be located as close as possible to the mixing pump **[in-line static mixer]**.
 7. Piping shall be included to completely drain the container and discharge into the LACT charging pump suction after the sample analysis is concluded.

3.05 METERS

- A. The custody transfer meter shall be a Coriolis mass flow type meter or positive displacement meter selected for the planned service conditions of working pressure and flow capacity. The wetted parts of the meter shall be stainless steel.
 1. **The meter case and trim specifications shall be selected for the planned service conditions of working pressure and flow capacity and be made of corrosion-resistant materials.**
 2. **A low-torque pulsing switch to operate the flow monitoring and proportional sampling systems shall be attached to the barrel unit register wheel or the meter shaft.**
- B. Meters shall have a repeatability of plus or minus 0.05 percent (0.0005), and a linearity of plus or minus 0.15 percent (0.0015) over the range of operating flow rates.
- C. The meter shall have a failure logic function to discontinue and lock out flow through the meter.
- D. Low and high flow rate alarm logic shall be provided.
- E. Meter set stop control shall be provided for complying with regulatory production allowables.

3.06 METER TEMPERATURE DEVICES

- A. Temperature transmitters shall have a range suitable for the operating conditions and shall have an accuracy within 0.2 °F under all operating conditions and an output resolution of 0.1 °F or better.
- B. The transmitter wiring shall be continuous between the transmitter and the PLC control unit.
- C. Temperature devices and thermowells shall be mounted to allow a filling with a conductive fluid, extend into the center third of the pipe, installed in the same size pipe as the meter piping within 12 inches from the meter outlet flange.
- D. Test thermowells shall be located within 8-12 inches of the transmitter thermowells.

3.07 FLOW COMPUTER/PLC CONTROL UNIT

- A. The equipment shall perform the following functions:
 - 1. Temperature displayed to a resolution of 0.01°F to facilitate calibration of sensors.
 - 2. Pressure displayed to a resolution 0.1 psi to facilitate calibration of sensors.
 - 3. Pulse generation and counting for proving.
 - 4. Failure detection.
 - 5. Set stop accumulation.
 - 6. Low/high flow rate alarms.
 - 7. Sample pacing.
 - 8. Flow accumulation.
 - 9. Capability for diagnostic activities including display of all units, conversion factors, correction factors, and outputs.
 - 10. Memory to store 50 hours of historical data.
- B. Flow computers used for custody transfer registration shall display an accumulated volume within one barrel of the metered flow.
- C. A standalone volume weighted temperature averager shall be installed on the LACT unit. LINCO TA-1000 or equivalent.

3.08 PROVER MANIFOLD

- A. A three-valve arrangement is required for single meter installations including:
 - 1. One isolation valve on the inlet and outlet lines to the prover with full opening design no smaller than the line size.
 - 2. A block and bleed (center) valve that shall be a full opening double block design with internal bleed for leakage check. Valve shall have a full opening design no smaller than the line size
 - 3. Cam and groove connections with dust caps for quick coupling to portable proving equipment.

4. Drain capability at each connection.
 5. Drain pan under or enclosure around the prover connections to collect any leaks.
- B. All piping components shall be designed to minimize flow restriction during proving operation.

3.09 LOCKS AND/OR SEALS

- A. Locks and/or seals shall be used to restrict the unauthorized entry to equipment involved with the quality or quantity measurement of custody transfer liquids. All means of entry into the operating stream, downstream of the charge pump, shall be locked and/or sealed to restrict or indicate unauthorized entry.
- B. Acceptable sealing devices are: padlocks, numbered lead wire seals, numbered ribbon car seals, epoxy or other hardenable inert sealing compound (for tubing and conduit fitting only), and rigid covers that are sealable.
- C. All equipment that could affect measurement quality or quantity except the charge pump, shall be sealed and/or locked.

3.10 INSTRUMENTATION AND ELECTRICAL

- A. All electrical wiring shall be in accordance with the National Electric Code (latest revision).
- B. The unit shall be completely wired using color coded wiring in rigid, corrosion-resistant, metallic conduit, complete with seal fittings. The conduit shall be securely attached to the skid and to the equipment items connected.
- C. Separate enclosures, suitable for the area classification, should be provided for power and operations controls and mounted on structural members attached to the skid.
- D. The power enclosure shall include:
1. 480 Volt AC three-phase circuit breakers.
 2. 1 KVA 240/120 volt AC single-phase control transformer
 3. 120 volt holding coil in the magnetic motor contactor, fuses, and control relays needed for pump operation.
 4. Dual, 3-wire grounded type, 120 volt AC convenience outlets with weatherproof covers externally mounted on the power enclosure.
 5. Fusible disconnect switch or circuit breaker in the power circuit connected to the door handle so that the power circuit is broken when the door is opened.
 6. Barrier type terminal blocks for connecting external wiring.
- E. The control enclosure shall include:
1. A selector switch furnished in the control enclosure, wired to bypass all the automatic shutdown control features except the set-stop allowable counter and the meter monitor circuit.
 2. Indicator lamps.
 3. Reset and test circuit switches and associated controls relays.

- 4. Barrier type terminal blocks for connecting external wiring.
- F. The main power circuit breaker should contain three properly sized overload relays of bimetallic type, and shall have a reset, either internal or external to the power panel.
- G. Plug-in type relays with contacts rated 10A, 120V AC and coils rated 40°C continuous duty, should be used between control signals and operated devices.
- H. Externally mounted lightning arrestor shall be furnished on the power enclosure
- I. Secondary electric power (battery backup) for at least 4 hours of field operation shall be provided.
- J. A low pressure switch at the inlet of the LACT unit shall be provided to shut down the charge pump upon low pressure.
- K. A charging pump control “Hand-OFF-Automatic” selector switch shall be provided.
- L. A lock-out function “Reset” switch shall be provided.
- M. A rotating type, weather-proof, colored lens, alarm beacon light should be mounted approximately six feet (two meters) above the skid. The alarm circuit should light the beacon whenever delivery from the unit is shut down due to a malfunction.
- N. A wiring diagram shall be provided including full identification of all electrical items and identification of the wire color used at each termination.

3.11 MARKING

- A. LACT units shall be identified by a name plate securely attached to the power control panel in a conspicuous place. Markings shall be either raised or stamped at least 1/8 inch high. The name plate shall contain the following information:
 - 1. Fabricator’s name.
 - 2. Design flow rate in GPM or B/D.
 - 3. Date of fabrication.

4.00 METER OPERATIONS AND PROVING

4.01 OPERATION

- A. For batched operations the meter shall be operated within the following conditions from the previous proving or shall be recalibrated to capture the new operating conditions.

1. Gravity	+/- 3° Corrected API
2. Flow Rate	+/- 10%
3. Pressure	+/- 20% or 50 PSIG whichever is less
4. Temperature	+/- 5° F
5. Volume	Not to exceed 250,000 per meter

- B. For lease operations measurement equipment shall be verified and / or calibrated by the following guidelines.
 - 1. Zero (0) to 5,000 barrels per month Quarterly
 - 2. 5,000 to 7,500 barrels per month Every Two (2) Months
 - 3. 7,500 to 250,000 barrels per month Monthly
 - 4. 250,000 barrels and above Not to exceed 250,000 bbls per meter
- C. For truck receipt locations the same guidelines shall apply with the addition that the meter proving shall be performed at no more than 3° corrected API gravity from the previous sample pots corrected API gravity.

5.00 METER TICKETS

5.01 REQUIREMENTS

- A. A meter ticket shall be written, monthly upon the first day of each month (meter tickets can be written more frequently during the month if required by quality monitoring, meter proving, and loss/gain surveillance). A meter ticket shall be written on a batch basis for every batch delivered to Oryx. Should batch movements extend over 7:00 A.M. month end, custody tickets will be taken at month end for closing purposes even though the entire batch may not be completed at that time.
- B. At a minimum, each meter measurement ticket shall include the following information:
 - 1. Date(s) and time(s) of start and end of batch
 - 2. Delivery location
 - 3. Name of shipper
 - 4. Name of carrier
 - 5. Indicated quantity of product transferred
 - 6. Gross quantity of product transferred (in barrels or gallons)
 - 7. Net quantity of product transferred (in barrels or gallons)
 - 8. Weighted average temperature (degrees F to tenth decimal point)
 - 9. Weighted average density (degrees API to tenth decimal point)
 - 10. Weighted average pressure (psig to tenth decimal point)
 - 11. Meter factor (to the ten-thousands decimal point)
 - 12. BS&W % (composite sample)
 - 13. Persons name(s) who performed measurement activity
- C. If the metering facility is not equipped with a pressure averaging device the "composite meter factor" which has been corrected for the normal operating pressure shall be used rather than the "meter factor".

6.00 **INSTALLATION**

6.01 **ELECTRICAL WIRING**

- A. All electrical wiring shall be in accordance with the National Electric Code (latest revision). Instrumentation and control wiring shall be routed separately and away from AC power cables and electrical noise generating equipment such as power transformers. Wire shall be 2, 3, 4 or more pair, as required for the specific field instrument.
- B. A spare pair is recommended with each wiring circuit. Each pair shall be labeled with durable material on each with loop and service designations. Wiring pairs shall be individually shielded and coated. Minimum wire size shall be No. 16 AWG cable or larger, except for the BS&W monitor cable. Multiple pairs shall be twisted at least twice per foot and shall be color-coded. Shielding shall be maintained to within one inch of the terminal connections.
- C. Terminal strips shall be used for all signal and power terminations. Terminations shall be made with tin-plated components and shall be labeled, numbered, or otherwise identified to give pertinent functional information.
- D. Electronic transmitters with analog circuits shall be installed in temperature controlled enclosures or incorporate temperature compensation capability to minimize the effects of ambient temperature changes to the electronics.
- E. Junction boxes shall be designed for pulling cable without the use of terminations. Splices, terminations, or solder connections shall not be allowed between the device and the sensor, except as required for field connections. Use only the coaxial cable length provided with the BS&W monitor. Modification of the cable length will require a full recalibration by the manufacturer.
- F. All panel mounted instruments and shields shall be individually grounded to the facility ground system using insulated NO. 14 AWG, or larger copper ground wires. Shields shall not be grounded at the individual instruments. Each individual electronic device shall have power transient (lightning) protection devices. Flow computers and electronic 76 averaging devices shall have appropriate surge protectors on each input circuit.
- G. Primary electric power shall be furnished from a regulated power supply with surge protection.

6.02 **CONTROLS**

- A. The following automatic control functions shall be provided:
- B. Start and stop the charging pump on receipt of signals from the respective surge tank level control(s).
- C. If re-treating line is included, divert clean oil to delivery discharge only on receipt of a positive signal from the BS&W, and deliver to the wet oil discharge otherwise.
- D. Restart on receipt of full power following a power outage period.
- E. Stop on receipt of signal indicating either (a) low flow rate, (b) meter failure, (c) monitor failure, (d) set-stop allowable counter zero, or (e) high pressure limit exceeded, and remain locked out until a manual reset is activated.

7.00 APPENDIX - TYPICAL LACT UNIT

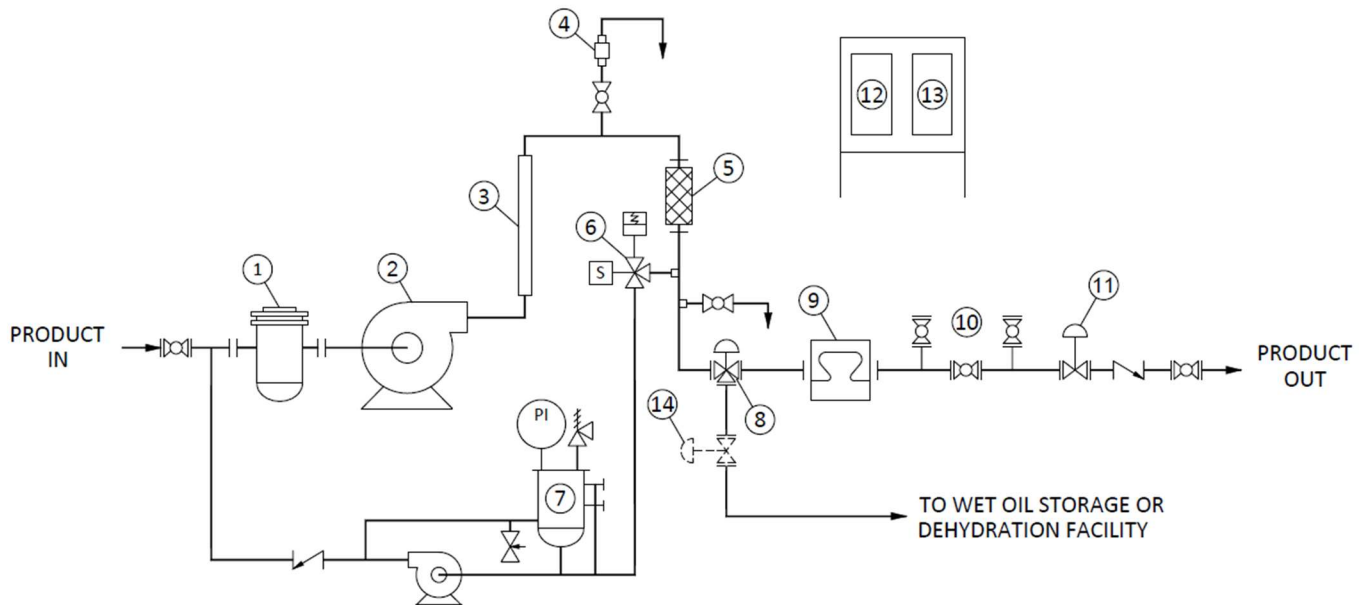

Figure A-1: Typical LACT Unit Schematic

- | | |
|---|--|
| <ol style="list-style-type: none"> 1. Strainer – Section 2.01G.4 2. Charge pump and motor – Section 3.02 3. BS&W monitor – Section 3.03 4. Air/Gas Eliminator – Section 2.01G.4 5. Static mixer – Section 2.01G.5 6. Sample extraction system – Section 3.04 7. Sample container and circulation system – Section 3.04D 8. Diverter valve – Section 2.01G.3 | <ol style="list-style-type: none"> 9. Custody transfer meter and accessories – Section 3.05 10. Prover system connections and accessories – Section 3.08 11. Back pressure valve – Section 2.01G.7 12. Power panel – Section 3.10 13. Control panel and equipment – Section 3.10 14. ‘Wet oil’ pressure valve (if specified) – Section 2.01G.7 |
|---|--|

END OF SECTION